



**WHEELCHAIR HANDBALL  
RULES FOR EUROPEAN  
TOURNAMENTS**

---



## TABLE OF CONTENT

---

Introduction.....	3
<b>1. Basics.....</b>	<b>3</b>
1.1. The Game.....	3
1.2. The Team.....	3
1.3. Players.....	3
1.4. Playing Time.....	3
1.5. The Ball.....	3
1.6. The Court.....	3
1.7. Goal.....	4
1.8. Equipment.....	4
1.9. Playing Kit.....	4
<b>2. Wheelchair Specifications.....</b>	<b>5</b>
<b>3. Regulations.....</b>	<b>6</b>
Protests & Appeals.....	6
<b>4. The Game.....</b>	<b>8</b>
4.1. Playing the ball.....	8
4.2. Violations.....	9



## Wheelchair Handball Rules for European Tournaments

### Introduction

The proposal for “Wheelchair Handball Rules for European Tournaments” basically follows the IHF rules of the Game.

No special “rules” shall apply despite having mixed teams. However, due to the different capability of players, the amendments listed below shall be implemented and will be used for the upcoming Wheelchair Handball European Tournaments.

### 1. Basics

#### 1.1. The Game:

Wheelchair Handball is played by two teams of 6 players including 1 goalkeeper per team. The aim of each team is to score goals and to prevent the other team from scoring.

Wheelchair Handball shall be based on the Fair Play spirit, dedicated for players with physical impairments.

#### 1.2. The Team

A team delegation consists of a maximum of 15 persons including a maximum of 12 players.

Minimum 3 female players shall be part of the team. Five field players and one goalkeeper including min. one female field player have to be on the court.

#### 1.3. Players

Players have to verify their status during the technical meeting by presenting a national classification confirmation from their responsible national authority. All officials have to be aware of the status of the players.

Players shall be min. 15 years old; written permission from the parents for players aged 16-18 years shall be presented prior to the tournament.

#### 1.4. Playing Time

Matches will be played with two halves of 20 minutes each.

The half-time break will be 10 minutes.

Each team has the right to receive one 1-minute team time-out in each half of the regular playing time. The team requesting a team time-out must be in the possession of the ball. Two team time-outs (one team time-out in each half) are granted.

#### 1.5. The Ball

The Tournament will be played with size 2 balls following the official IHF dimensions.

#### 1.6. The Court

The minimum base area should be 44 metres long and 25 metres wide. The court and line system are identical to the general handball court: 40 metres long and 20 metres wide. The substitution area should be 4.5 metres wide. The ‘safe zone’ on a side of the court should be 3 metres wide.



#### **1.7. Goal:**

Goals shall be adapted to the size 3m x 1,7m by using stable bars. The catch net in the goals shall be removed (or fixed to the goal net) in order to avoid entangling with the wheelchair.

#### **1.8. Equipment**

The following material is not permitted:

- Glue for handling the ball
- Protective equipment if including metal components
- Prostheses
- Finger, hand, wrist, etc. braces made of plastic, metal, etc.

It is permitted to use:

- Hand gloves (soft, without any support, etc.)
- Protective equipment if padded / soft (not including metal)
- Glasses
- Taping band for fingers, arms, etc.

However all equipment shall be presented on the occasion of the technical meeting for a final decision.

The IHF Regulations regarding the protective equipment shall be adapted.

#### **1.9. Playing kit**

Each team shall arrive with 2 playing kits (one light colour / one dark colour). The player shirts shall have the player's number on the front of the shirt (height of 10cm). The number of the player shall be placed on the back of the wheelchair as well (height of 20cm).



## 2. Wheelchair Specifications

The wheelchairs shall be constructed in a safe and fair way without any risk for the player himself, his team colleagues or the opponent team. A wheelchair can be banned from the game if there is any concern about its safety or fairness (referee decision).

The following specifications shall apply:

- The wheelchairs shall be constructed in a safe and fair way without any risk for the player himself, his team colleagues or the opponent team. A wheelchair can be banned from the game if there is any concern about its safety or fairness (referee decision).
- A horizontal bar shall be placed at the front of the wheelchair (approx. 11cm from the floor). However it is mandatory to use a complete wing covering the front and side of the wheelchair in order to protect the players.
- 1 – 2 anti-dip devices shall be attached to the wheelchair.
- The maximum height (from the floor to the top of the cushion or seat platform) shall not exceed 63cm.
- 5 – 6 wheels (2 large wheels in the rear, one or two at the front and two safety wheels on the back. Max. diameter of large wheels: 71cm (28 inches)
- 1 hand rim on each wheel obligatory
- Both wheels need to be fully covered
- Padding of bar at back of the backrest (15mm);
- If a wheelchair is no longer functional or unsafe the player has to leave the field for any repairs.

### Straps

Players have to be strapped to the wheelchair at the upper and lower legs in order to avoid lifting or moving/using the legs.

Lifting of field players when playing / defending the ball will be punished with 2min suspension; lifting of the goalkeeper while defending will be punished with 2min. suspension and the awarding of a 7m throw.

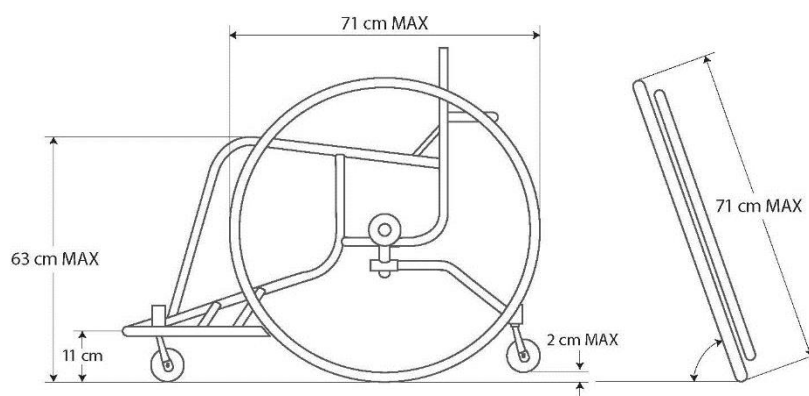



### 3. Regulations

Winner of the match: the team that has scored more goals at the end of playing time shall be determined the winner.

Two points are awarded for a win, one point for a draw and zero points for a defeat.

Winner of the Tournament: the Tournament will be played according to the round-robin-system (each team playing each opponent) followed by the final match (team ranked one vs. team ranked two) and the match 3 / 4 (team ranked three vs. team ranked four).

If two or more teams are equal on points their ranking is determined as follows:

- a) Higher number of points obtained in the matches played amongst the teams in question
- b) Superior goal difference from the matches played amongst the teams in question
- c) Higher number of goals scored in the matches played amongst the teams in question
- d) Superior goal difference from all matches
- e) Higher number of goals scored in all group matches

Final Match and the Placement Matches (K.O. system):

In case of a draw no extra time shall be played. The match will be decided by a 7-meter-throw as tie-breaker following the procedure in paragraph 2:2 - IHF Rules of the Game

### Protests & Appeals

#### Protests

- The EHF delegate has the right and the obligation to act as juridical body of first instance with regard to any protest related to matches of the Wheelchair Handball Nations' Tournament.
- Any protest regarding any of the Wheelchair Handball Nations' Tournament matches shall be submitted in writing to the responsible EHF delegate within one (1) hour after the end of the relevant match.  
Moreover a protest fee of € 1,000 shall be paid by the claimant to the EHF. Such amount shall be paid directly to the EHF delegate or shall be transferred to the EHF bank account at the same time the protest is submitted. A written proof of payment of the protest fee provided within the aforementioned deadline shall be deemed sufficient.
- If the protest is fully granted, the protest fee is refunded to the claimant; otherwise it is forfeited to the credit of the EHF.
- The reasons for the protest as well as any relevant statement and document shall be submitted in writing to the responsible EHF delegate by the claimant in one of the three official EHF languages no later than 9.00 am local time the day after the relevant match.
- The EHF delegate takes a decision on the protest which may include inter alia disqualification of players or teams no later than 12.00 pm (noon) local time the day after the relevant match. Such decision is announced to the relevant parties.



### Appeals

- Any decision taken by an EHF delegate according to the aforementioned provisions may be appealed to the EHF Court of Appeal, acting through an Ad Hoc Commission.
- An appeal against a decision of an EHF delegate shall be filed with the EHF Office and shall be requested to the EHF delegate in writing no later than 8.00 pm local time the same day the EHF delegate decision is announced to the relevant parties.
- Moreover an appeal fee of € 1,000 shall be paid by the appellant to the EHF. Such amount shall be paid directly to the EHF delegate or shall be transferred to the EHF bank account at the same time the appeal is filed/requested. A written proof of payment of the appeal fee provided within the aforementioned deadline shall be deemed sufficient.
- If the appeal is fully granted, the appeal fee is refunded to the appellant; otherwise it is forfeited to the credit of the EHF.
- The appeal request is transferred to the EHF Court of Appeal Ad Hoc Commission. The Ad Hoc Commission takes a decision by simple majority following an express written procedure no later than 12.00 pm (noon) local time the day following the filing of the appeal. Such decision is communicated in writing to the relevant parties.
- The EHF Court of Appeal Ad Hoc Commission consists of three (3) members of the EHF Court of Appeal nominated by the President of the EHF Court of Appeal before the beginning of the respective tournaments.
- They may be challenged in accordance with the EHF Legal Regulations.
- The EHF delegate having decided on the protest at first instance shall not be part of the Ad Hoc Commission examining the protest in appeal.
- The Ad Hoc Commission members are not present at the relevant venues.

### EHF regulations infringements / disciplinary cases

- If deemed appropriate by the EHF, to ensure the proper running of the EHF Wheelchair Handball Nations' Tournament and/or respect of the applicable regulations during the EHF Wheelchair Handball Nations' Tournament, violations of the present regulations and/or other EHF regulations applicable to Wheelchair Handball Nations' Tournament by any team, delegation, individual and/or EHF Officials as well as direct disqualification cases are examined, decided upon and sanctioned by the EHF delegate and the EHF Court of Appeal Ad Hoc Commission (in appeal) following an express procedure.
- In those cases, the deadlines defined here above are not applicable.
- The provisions of the EHF Legal Regulations, the EHF List of Penalties and the Catalogue of Administrative Sanctions apply for all administrative, legal and disciplinary offences committed by the teams, individuals and/or EHF Officials, unless the present regulations stipulate otherwise.



#### 4. The Game

##### 4.1. Playing the ball

It is permitted to

- throw, catch, stop, push or hit the ball by using hands, arms, head and torso,
- hold the ball for a maximum of 3 seconds,
- push the wheelchair and dribble the ball,
- place the ball on the lap (not between the knees) while pushing the wheelchair max. within 3 seconds (no longer),
- to monitor and follow the opponent (with or without ball) by using arms and hands as long as the opponent has enough time and distance to react and no danger is present.
- block or force away an opponent with arms or hands, wheelchair (when player is not in great speed)
- enter the goal area or cross the side-lines without the ball after a shot or after being pushed when not causing an advantage doing so; the player has to leave the goal area as soon and fast as possible.

It is not permitted to

- after the ball has been controlled, to touch it more than once, unless it has touched the floor, another player, or the goal in the meantime (13:1a); however, touching it more than once is not penalized, if the player is “fumbling” the ball, i.e., failing to control it when trying to catch or stop it;
- by the same player to start bouncing after a throw before another player or a goalpost touched the ball
- stop the ball with wheelchair
- enter the goal area with the ball under control (as player)
- cross the side-line with the ball under control (the wheelchair has to be IN the field)

##### **Remarks:**

*The wheelchair can be pushed max for 3 seconds; it is allowed to place the ball on the lap during these pushes. A ball on the lap is considered as “under control”. The opponent is therefore not allowed to take the ball off the laps.*

*After receiving the ball the player has to start the action with bouncing.*

*Pushes mean pushing/moving the wheel. When the hand leaves the wheel the next action (dribbling, passing, shooting) has to follow within 3 seconds. It is not allowed to touch the wheel again after those 3 seconds.*

*As in indoor Handball it is not allowed to hold the ball for more than 3 seconds.*

*In case a ball is thrown against a wheelchair or covered under a wheelchair the referees have to decide on the intention and the respective consequences.*

*It is allowed to use/touch the wheelchair for picking up the ball.*

*The new rules regarding goalkeeper, 30 seconds and passive play shall be included.*





#### 4.2. Violations

Violations shall be handled according to the IHF Rules of the Game:

- Yellow Card
- 2 Minutes Suspension
- Disqualification
- Team Penalty

It is permitted

- to use an open hand to play the ball out of the hand of another player;
- to use bent arms to make body contact with an opponent, and to monitor and follow him in this way;
- to use one's wheelchair to block the opponent, in a struggle for positions;

It is not permitted to

- to pull or hit the ball out of the hands of the opponent
- to block the opponent with arms, hand, legs, wheelchair or to use any part of the body to displace him or push him away; this includes a dangerous use of the elbow, both as a starting position and in motion;
- to hold an opponent (wheelchair, body or uniform), even if he remains free to continue the play;
- endanger an opponent

#### **Remarks:**

*Attacker foul will be handled as in indoor (intention / no intention). Blocking and opponent by holding the wheelchair will be punished progressively.*

*Front contacts are tolerated, but the side and rear contacts must be punished. For all these faults, the chair is considered as part of the player and the non-accidental contact between chairs also constitutes a foul.*

*7m shots, free throw, etc. have to be placed behind the respective line. Touching or passing the lines will be handled as in indoor handball. However, crossing the substitution line shall not be handled too strictly.*

*Just in case of exclusion, disqualification and if the team precedes substitutions during the period inherent in these disciplinary penalties, the team score, **adding sanctioned players**, can never exceed the total score of classification (24 points).*

#### Fouls that warrant a personal punishment under Rules 8:3-6

8:3 Fouls, where the action is mainly or exclusively aimed at the body of the opponent, must lead to a personal punishment. This means that, in addition to a free-throw or 7-meter-throw, at least the foul is to be punished progressively, beginning with a warning (16:1), then with 2-minute suspensions (16:3b) and disqualification (16:6d).



#### Fouls that warrant an immediate 2-minute suspension

8:4 For certain fouls, the punishment is a direct 2-minute suspension, regardless of whether the player had received a warning earlier.

This applies especially for such fouls where the culpable player disregards the danger to the opponent (see also 8:5 and 8:6);

Taking into account the decision-making criteria under 8:3, such fouls could for instance be:

- fouls that are committed with high intensity or against an opponent who is “driving” fast;
- holding on to the opponent for a long time, or pulling him down;
- fouls against the head, throat or neck;
- hard hitting against the torso or throwing arm;
- attempting to make the opponent lose body control
- driving the wheelchair in great speed into an opponent

#### Fouls that warrant a disqualification

A player who is attacking an opponent in a way that is dangerous to his health is to be disqualified (16:6a). The special danger to the opponent’s health follows from the high intensity of the foul or from the fact that the opponent is completely unprepared for the foul and therefore cannot protect himself (see rule 8:5 comment).

In addition to the criteria of 8:3 and 8:4, the following decision-making criteria also apply:

- the actual loss of body control while running or jumping, or during a throwing action;
- a particularly aggressive action against a part of the body of the opponent, especially face, throat or neck; (the intensity of the body contact);
- the reckless attitude demonstrated by the guilty player when committing the foul.

During the game, in no case is the athlete allowed to rise from the chair (it is compulsory use of a belt fixing to the chair).

The disqualification of a player or team official is always for the entire remainder of the playing time. For details please see IHF Rules of the game

The referees shall use the international hand signals.

The referees will give special attention to the safety of all players as well as to fairness.

For safety reasons the referees will not whistle directly on the playing court but shall officiate from the side-line and goal line.

22.05.2018/Kob